

Technical data sheet

Flow meter FMO



More than just pumps

Flow meter FMO



Advantages/characteristics:

- ▶ Oval rotor design
- ▶ For low-viscosity to high-viscosity media
- ▶ With integrated digital display unit FLUXTRONIC® or available as pulse version
- ▶ Depending on type for use with drum/eccentric worm-drive pump or for use in piping
- ▶ Flow rate of 0,04 - 380 l/min
- ▶ High accuracy and repeat accuracy
- ▶ Signal transduction at FLUXTRONIC® or other external control e. g. PCC possible
- ▶ Display in litre, gallon or kilogram possible
- ▶ Semiautomatic filling in connection with a switching amplifier possible
- ▶ For Ex-application in Zone 1
- ▶ Depending on type also suitable for food contact according to EG 1935/2004 and FDA CFR 21

Technical data/type	FMO 101			FMO 102			FMO 104		
	P/P	P/S	S/S	P/P	P/S	S/S	AL/P	S/P	S/S
Description									
Connection inlet/outlet	G 1/4						G 1/2		
Material									
Housing	PVDF	PVDF	S	PVDF	PVDF	S	AL	S	S
Oval rotors	PPS	S	S	PPS	S	S	PPS	PPS	S
Shaft	HC	S	S	HC	S	S	S	S	S
Seal	FKM/FFKM/EPDM								
Viscosity max. [mPas]	up to 1.000						up to 1.000 / from 1.000 up to 500.000		
Flow rate l/min at viscosity < 5 mPas at viscosity > 5 mPas	0,09-1,67 0,04-1,67			0,44-8,3 0,25-8,3			2-25 1-30		
Measurement error of the flow rate ⁽¹⁾ < 5 mPas > 5 mPas	± 2,5 % ± 1 %						± 2 % ± 0,5 %		
Repeat accuracy ⁽²⁾	± 0,03 %								
Pulse/litre (theo.)	2.170			390			100		
Theo. calibration constant [L/Imp]	0,0004608			0,0025641			0,0100000		
Medium temperature [°C] (for non Ex-application and Ex-application with pulse version)	-10 to +60	-30 to +120		-10 to +60	-30 to +120		-30 to +80	-30 to +120	
Medium temperature [°C] (for Ex-application with FLUXTRONIC®)	-						-20 to +40		
Ambient temperature [°C]	-20 to +40								
Operating pressure max. [bar]	10	100		10	100		130	200	
Protection class [IP]	54								
Ex-marking	II 2G Ex h IIB T4 Gb			II 2G Ex h IIB T4 Gb			II 2G Ex ia IIB T6 Gb		
Weight [kg]	0,2	0,2	0,7	0,2	0,2	0,6	1,6	4,1	4,2
Sensor	Reed/Hall						Reed/Reed*		
Approvals	-	-	-	-	-	-	-	-	-



⁽¹⁾ Difference between the average measured values of a series of the measurements and the theoretical value

⁽²⁾ Bandwidth between several measurements under identical conditions

* Version Reed/Reed or Hall/Hall possible

Technical data sheet

Flow meter FMO 110/140/150

Technical data/type	FMO 110					FMO 140			FMO 150			
	P/P	AL/P	S/P	S/S	S/S	AL/P	S/P	S/S	AL/P	S/P	S/S	
Description												
Connection inlet/outlet	G 1				Clamp 1 1/2"	Clamp 2"	Flange DIN 1092 PN16/DN40 A150/ LK110/ holes 4x ø18 mm			Flange DIN 1092 PN16/DN50 A165/ LK125/ holes 4x ø18 mm		
Material												
Housing	PVDF	AL	S		S	AL	S	S	AL	S	S	
Oval rotors	PPS	PPS	PPS		S	PPS	PPS	S	PPS	PPS	S	
Shaft	HC	S	S		S	S	S	S	S	S	S	
Seal	FKM / FFKM / EPDM											
Viscosity max. [mPas]	up to 1.000 / from 1.000 to 500.000											
Flow rate l/min at viscosity < 5 mPas at viscosity > 5 mPas	9,5-150 5,7-170					15-227 9,5-245			23-380 15-380			
Measurement error of the flow rate ⁽¹⁾ < 5 mPas > 5 mPas	± 2 % ± 0,5 %					± 1 % ± 0,5 %						
Repeat accuracy ⁽²⁾	± 0,03 %											
Pulse/litre (theo.)	45					17			9			
Theo. calibration constant [L/Imp]	0,0222222					0,0588235			0,1111111			
Medium temperature [°C] (for non Ex-application and Ex-application with pulse version)	-10 to +60	-30 to +80	-30 to +120			-30 to +80	-30 to +120	-30 to +80		-30 to +120		
Medium temperature [°C] (for Ex-application with FLUXTRONIC®)	-10 to +40	-20 to +40										
Ambient temperature [°C]	-20 to +40											
Operating pressure max. [bar]	10	130	200	16		16						
Protection class [IP]	54											
Ex-marking	II 2G Ex h IIB T4 Gb											
Approvals	-	-	-	-			-	-	-	-	-	-
Weight [kg]	1,5	1,7	4,3	4,5	4,5	5,1	13,4	13,9	5,8	15,2	16,2	
Sensor	Reed/Reed*											

⁽¹⁾ Difference between the average measured values of a series of the measurements and the theoretical value

⁽²⁾ Bandwidth between several measurements under identical conditions

* Version Reed/Reed or Hall/Hall possible

Dimensions

Flow meter FMO

Dimensions [mm]

FMO 101/102 (without FLUXTRONIC®)

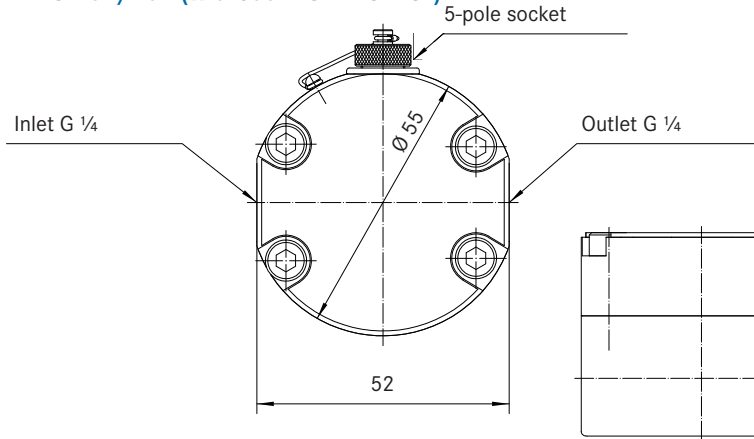

Measure	H	Z
FMO 101/102 P	48	16
FMO 101/102 S	44	13

FMO 104/110 (with FLUXTRONIC®)

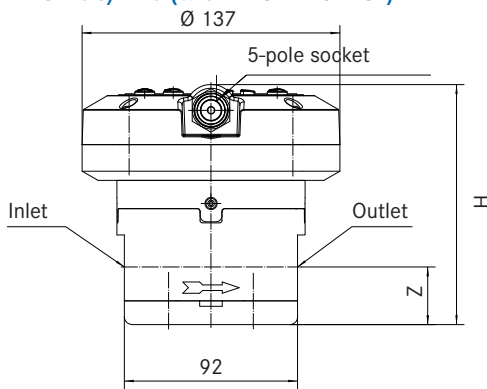

Measure	H	Z
FMO 104	128	31
FMO 110	139	39

FMO 104/110 in pulse version (without FLUXTRONIC®)

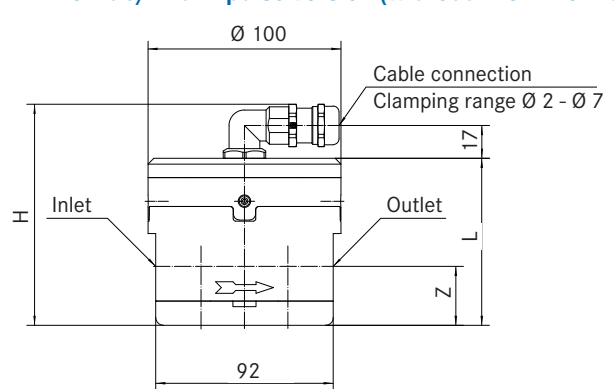

Measure	H	Z	L
FMO 104	115	31	87
FMO 110	126	39	98

FMO 104/110 with Clamp (with FLUXTRONIC®)

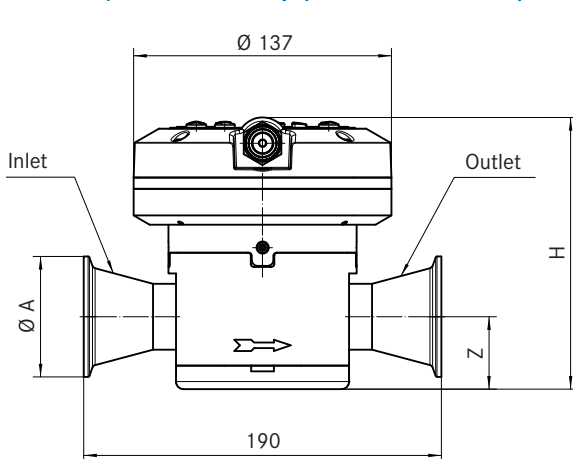

Measure	H	Z
FMO 104	134	31
FMO 110	144	39

FMO 140/150 (with FLUXTRONIC®)

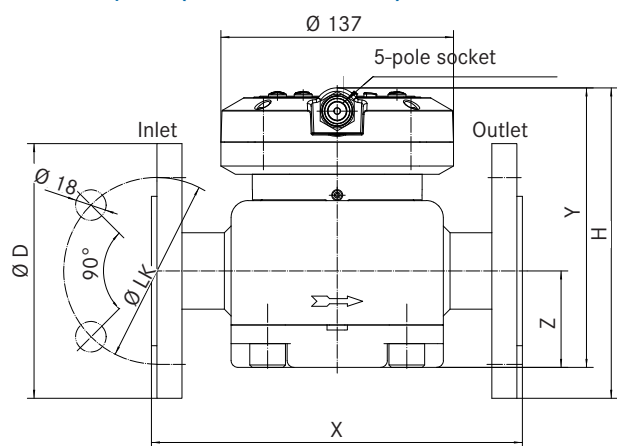

Measure	Ø D	Lk	H	X	Y	Z
FMO 140	150	110	189	212	171	57
FMO 150	165	125	202,5	264	181	61

Part numbers

Flow meter FMO



More than just pumps

For media with viscosities up to 1.000 mPas

Flow meter with FLUXTRONIC®

Material	Seal	FMO 104	FMO 110			FMO 140	FMO 150
Connection		G ½	G 1	Clamp 1 ½"	Clamp 2"	Flange DN 40	Flange DN 50
AL/P	EPDM	10-A06 04 100	10-A06 10 100	-	-	10-A06 40 101	10-A06 50 101
	FKM	10-A06 04 110	10-A06 10 110	-	-	10-A06 40 111	10-A06 50 111
	FFKM	10-A06 04 120	10-A06 10 120	-	-	10-A06 40 121	10-A06 50 121
S/P	EPDM	10-A06 04 200	10-A06 10 200	-	-	10-A06 40 201	10-A06 50 201
	FKM	10-A06 04 210	10-A06 10 210	-	-	10-A06 40 211	10-A06 50 211
	FFKM	10-A06 04 220	10-A06 10 220	-	-	10-A06 40 221	10-A06 50 221
S/S	EPDM	10-A06 04 300	10-A06 10 300	10-A06 10302	10-A06 10303	10-A06 40 301	10-A06 50 301
	FKM	10-A06 04 310	10-A06 10 310	10-A06 10312	10-A06 10313	10-A06 40 311	10-A06 50 311
	FFKM	10-A06 04 320	10-A06 10 320	-	-	10-A06 40 321	10-A06 50 321
P/P	EPDM	-	10-A06 10 400	-	-	-	-
	FKM	-	10-A06 10 410	-	-	-	-
	FFKM	-	10-A06 10 420	-	-	-	-

Flow meter in pulse version (without FLUXTRONIC®)

Material	Seal	FMO 101	FMO 102	FMO 110	Material	Seal	FMO 104	FMO 110
P/S	EPDM	10-AB6 01 100	10-AB6 02 100	-	AL/P	EPDM	10-AB6 04 100	10-AB6 10 100
	FKM	10-AB6 01 110	10-AB6 02 110	-		FKM	10-AB6 04 110	10-AB6 10 110
	FFKM	10-AB6 01 120	10-AB6 02 120	-		FFKM	10-AB6 04 120	10-AB6 10 120
S/S	EPDM	10-AB6 01 300	10-AB6 02 300	-	S/P	EPDM	10-AB6 04 200	10-AB6 10 200
	FKM	10-AB6 01 310	10-AB6 02 310	-		FKM	10-AB6 04 210	10-AB6 10 210
	FFKM	10-AB6 01 320	10-AB6 02 320	-		FFKM	10-AB6 04 220	10-AB6 10 220
P/P	EPDM	10-AB6 01 400	10-AB6 02 400	10-AB6 10 400	S/S	EPDM	10-AB6 04 300	10-AB6 10 300
	FKM	10-AB6 01 410	10-AB6 02 410	10-AB6 10 410		FKM	10-AB6 04 310	10-AB6 10 310
	FFKM	10-AB6 01 420	10-AB6 02 420	10-AB6 10 420		FFKM	10-AB6 04 320	10-AB6 10 320

For media with viscosities from 1.000 to max. 500.000 mPas

Flow meter with FLUXTRONIC®

Material	Seal	FMO 104	FMO 110			FMO 140	FMO 150
Connection	-	G ½	G 1	Clamp 2"	Flansch DN 40	Flansch DN 50	
AL/PV	EPDM	10-A06 04 105	10-A06 10 105	-	10-A06 40 106	10-A06 50 106	
	FKM	10-A06 04 115	10-A06 10 115	-	10-A06 40 116	10-A06 50 116	
	FFKM	10-A06 04 125	10-A06 10 125	-	10-A06 40 126	10-A06 50 126	
S/PV	EPDM	10-A06 04 205	10-A06 10 205	-	10-A06 40 206	10-A06 50 206	
	FKM	10-A06 04 215	10-A06 10 215	-	10-A06 40 216	10-A06 50 216	
	FFKM	10-A06 04 225	10-A06 10 225	-	10-A06 40 226	10-A06 50 226	
S/SV	EPDM	10-A06 04 305	10-A06 10 305	10-A06 10307	10-A06 40 306	10-A06 50 306	
	FKM	10-A06 04 315	10-A06 10 315	10-A06 10317	10-A06 40 316	10-A06 50 316	
	FFKM	10-A06 04 325	10-A06 10 325	-	10-A06 40 326	10-A06 50 326	

Flow meter in pulse version (without FLUXTRONIC®)

FMO 104	FMO 110
-	-
10-AB6 04 105	10-AB6 10 105
10-AB6 04 115	10-AB6 10 115
10-AB6 04 125	10-AB6 10 125
10-AB6 04 205	10-AB6 10 205
10-AB6 04 215	10-AB6 10 215
10-AB6 04 225	10-AB6 10 225
10-AB6 04 305	10-AB6 10 305
10-AB6 04 315	10-AB6 10 315
10-AB6 04 325	10-AB6 10 325

Connecting piece made of stainless steel (S)

To connect	Connection	Part no.
FMO 104 - FLUX drum pump	G ½ A - G 1 ¼	10-959 06 227
FMO 104 - FLUX eccentric worm-drive pump	G ½ A - G 1 ½	10-959 06 225
FMO 110 - FLUX drum pump	G 1 A - G 1 ¼	10-959 06 144
FMO 110 - FLUX eccentric worm-drive pump	G 1 A - G 1 ½	10-959 06 122

Connecting piece made of polyvinylidene fluoride (PVDF)

To connect	Connection	Part no.
FMO 110 P/P - at FLUX drum pump	G 1 A - G 1 ¼	10-959 06 145

Technical data sheet

Digital display unit FLUXTRONIC®



Digital display unit FLUXTRONIC®



Advantages/characteristics:

- ▶ Simple operating concept
- ▶ All data will be maintained when replacing the battery
- ▶ Four safety levels with PIN setting
- ▶ Three additional outlets
- ▶ For mounting on flow meters, on nozzles or e.g. on the wall
- ▶ Calibration on medium possible
- ▶ Shows filled quantity (normal operation)
- ▶ With switching amplifier batch mode possible (automatic mode)
- ▶ Ex-proofed 

Technical data		
Ambient temperature	-20 to +40 °C (at temp. below 0 °C the LCD-display is slowed)	
Housing material	PP	
Pulse length	2 mS	
Power supply	Lithium battery CR 2032	
Protection class	IP 54	
Input	Mechanical contact (reedsensor) start/stop (button)	
Output	NAMUR: redirection, signal 1 – e. g. for motor, signal 2 – e. g. for valve, error signal OK signal	
Ex-marking	 II 2G Ex ia IIB T6 Gb	
Description	Part no.	
External digital display FLUXTRONIC® for FMO 101, FMO 102	10-001 42 111	
External digital display FLUXTRONIC® for FMO 104, FMO 110 in pulse version	10-001 42 113	
Protecting cap for FLUXTRONIC®	10-001 42 121	
Pulse cable for connecting the flow meter in pulse version with FLUXTRONIC®	5 m	10-934 08 032
	10 m	10-934 08 033
	15 m	10-934 08 034

Switching amplifier for non-Ex applications	
Description	Part no.
FSV 100 (2 signals*) for installation in flow meter	10-001 49 040
Connecting cable switching amplifier/motor	10-934 08 035
Connecting cable switching amplifier/magnetic valve	10-934 08 036
Connecting cable shielded 5 m FSV/external FLUXTRONIC®	10-934 08 030
Connecting cable shielded 10 m FSV/external FLUXTRONIC®	10-934 08 031
Switching amplifier for Ex-application	
Description	Part no.
FSV 121-1 Ex Ex-marking:  II 2(1) G Ex db eb [ia Ga] IIC T6 Gb	10-001 49 039
FSV 132 (2 signals*) for installation in the control cabinet Ex-marking:  II (1) G [Ex ia Ga] IIC	10-940 04 020
FSV 133 Ex (1 signal) for installation in the control cabinet for redirection Ex-marking:  II 3 (1) G Ex nAc nCc [ia] IIC T4	10-940 04 041
Control cable 5 m Flow meter/FSV	10-934 08 038
Control cable 10 m Flow meter/FSV	10-934 08 040

Maximal flow rate (l/min) for different viscosities and x bar pressure drop

Viscosity [mPas]	Pressure drop x [bar]	Type					
		FMO 101*	FMO 102*	FMO 104	FMO 110	FMO 140	FMO 150
1	1 *0,1 **0,5	1,67*	4*	23*	130	180**	380
< 140		0,24*	1,2*	7,6*	75	150	220
< 400		-	-	15,5	34	70	105
< 900		-	-	8,5	18	45	65
< 2.500	10	-	-	19	43	90	123
< 5.000		-	-	13	29	60	82
< 10.000		-	-	9	19	40	55
< 15.000		-	-	6	13	27	37
< 30.000		-	-	4	9	18	24
< 60.000		-	-	3	6	12	16
< 120.000		-	-	2	4	8	11
< 250.000		-	-	1	3	5	7
< 500.000		-	-	-	2	4	5

Mounting position FMO

When mounting the flow meter type FMO make sure that neither the bottom nor the cover of the meter housing will be ground off by the weight of the oval rotors.

